

# Common Terminals XW2R-COM

CSM\_XW2R-P\_M\_B-COM\_DS\_E\_1\_1

Space-saving and less wiring work of power supply wiring are achieved.

- Common wiring is already wired on the PCB, transition wiring is unnecessary.
- Wiring is completed by one action.
- Models available with +, -, + - Mix.



## Application Example

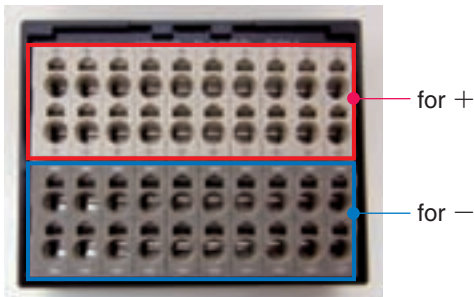

**Each terminal connected by PCB.**  
→ Bus-bar and transition wiring are unnecessary.

## Connection Examples

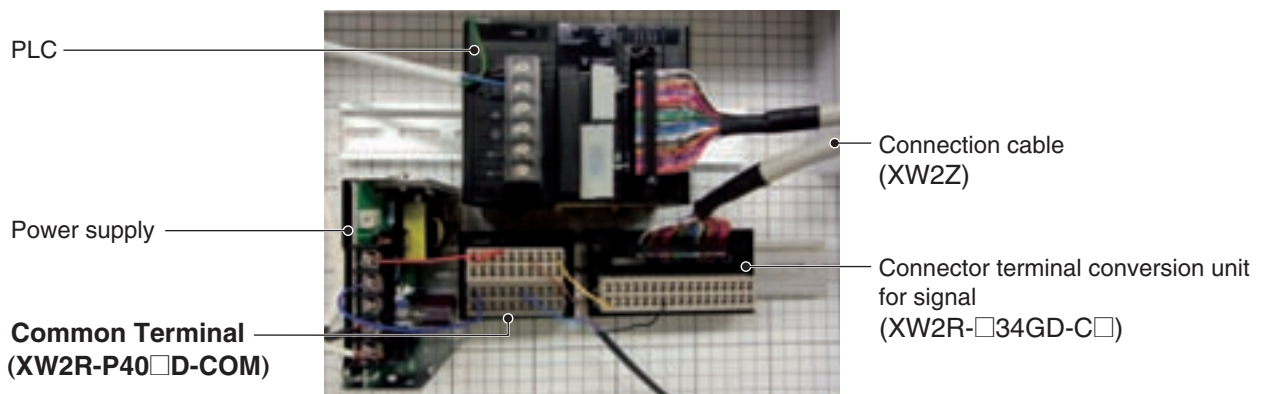



## Model list

XW2R - P 40 □ D - COM

| Wiring method |                | Terminal number of poles |          | Type of connector |          | Mounting method |                    | Power supply terminals (Common terminals) |          |
|---------------|----------------|--------------------------|----------|-------------------|----------|-----------------|--------------------|---|----------|
| P             | Push-in spring | 40                       | 40 poles | P                 | + Common | D               | DIN Track mounting | COM                                       | Provided |
|               |                |                          |          | M                 | - Common |                 |                    |   |          |
|               |                |                          |          | B                 | + - Mix  |                 |                    |   |          |

# XW2R

## Ordering Information

| Appearance  | Specification     | Number of poles | Model          |
|---|-------------------|-----------------|----------------|
|  | + Common terminal | 40              | XW2R-P40PD-COM |
|  | - Common terminal |                 | XW2R-P40MD-COM |
|  | + - Mix terminal  |                 | XW2R-P40BD-COM |

## Ratings and Specifications

|                               |   |
|-------------------------------|---|
| Rated current                 | 10A(Unit total)   |
| Rated voltage                 | 125VDC/240VAC   |
| Insulation resistance         | 100MΩmin. (at 500VDC)   |
| Ambient operating temperature | 0 to 55°C   |
| Applicable wires              | Applicable wire sizes<br>Ferrule:AWG24 to 14<br>(0.2mm <sup>2</sup> to 2mm <sup>2</sup> )<br>Stranded or solid wire:AWG 28 to 14<br>(0.08mm <sup>2</sup> to 2mm <sup>2</sup> )<br>(Outer diameter of insulation must be 4 mm max) |
|                               | Stripped length<br>AWG28-16: 8 to 10 mm<br>AWG14: 9 to 10 mm  |

### Details on Crimp Terminals

#### Applicable Ferrules

- Use ferrules of the lengths and thicknesses specified below. If other lengths or thicknesses are used, connection may not be possible or it may not be possible to insert or remove the posts.

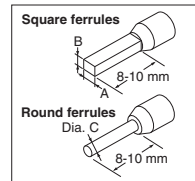

- Ferrule Dimensions

|                 |                        |                                 |   |
|-----------------|------------------------|---------------------------------|---|
| Square ferrules | Dimension A (Width)    | 2.7 mm max.                     | The cross-sectional area after crimping must be 4.8 mm <sup>2</sup> or less |
|                 | Dimension B (Height)   | 2 mm max.                       |   |
| Round ferrules  | Dimension C (Diameter) | 2 mm dia. max. (after crimping) |   |

Refer to page 3 for information on Square/Round ferrule and use tool.

## Dimensions

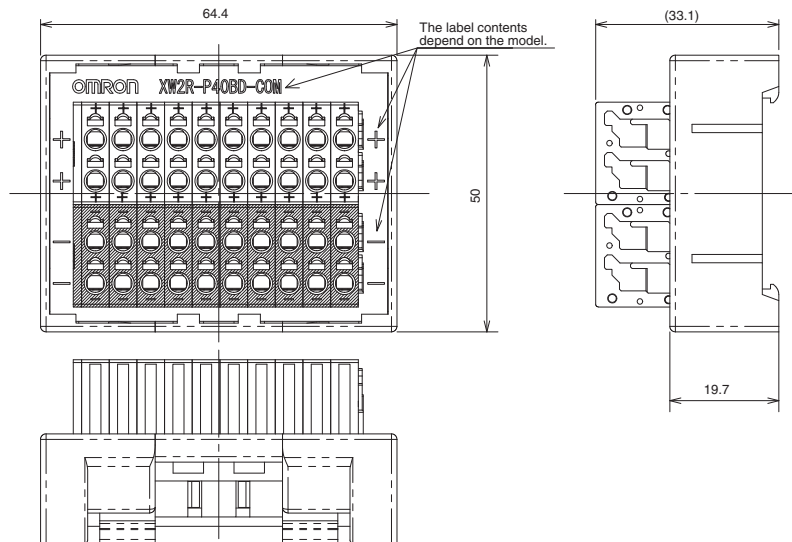

## Wiring Diagram

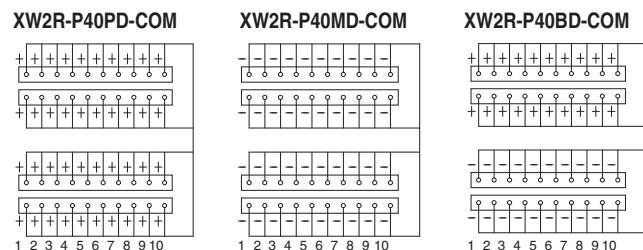

## Label Contents

|                |       |   |   |   |   |   |   |   |   |   |    |
|----------------|-------|---|---|---|---|---|---|---|---|---|----|
| XW2R-P40PD-COM | Upper | + | + | + | + | + | + | + | + | + |    |
|                | Lower | + | + | + | + | + | + | + | + | + |    |
| XW2R-P40MD-COM | Upper | - | - | - | - | - | - | - | - | - |    |
|                | Lower | - | - | - | - | - | - | - | - | - |    |
| XW2R-P40BD-COM | Upper | + | + | + | + | + | + | + | + | + |    |
|                | Lower | - | - | - | - | - | - | - | - | - |    |
|                |       | 1 | 2 | 3 | 4 | 5 | 6 | 7 | 8 | 9 | 10 |

## Safety Precautions

### Precautions for Correct Use

#### Wiring Precautions

- Do not perform wiring work, remove connectors, or connect connectors while power is being supplied. Electric shock or damage to the device may result.
- Double-check all wiring before turning ON the power supply.
- After wiring, route the cable so that force is not applied directly to the connections.

#### Wires for Terminal Blocks

- Do not damage the cores when stripping the insulation from them.
- Always twist stranded wires together before connecting them.
- Do not presolder wires. It may not be possible to connect them or remove them.

#### XW2R-P□□ type (Square/Round ferrule)

| Type of terminal | Manufacturer    | Size            | Recommend ferrule         | Recommend crimp tool |
|------------------|-----------------|-----------------|---------------------------|----------------------|
| Square ferrule   | Phoenix Contact | AWG24           | AI0.25-8□□                | CRIMFOX6             |
|                  |                 | AWG22           | AI0.34-8TQ                |                      |
|                  |                 | AWG20           | AI0.5-10WH<br>AI0.5-8WH   |                      |
|                  |                 | AWG18           | AI0.75-10GY<br>AI0.75-8GY |                      |
|                  |                 | AWG16           | AI1.5-10BK                |                      |
|                  |                 | AWG14           | AI2.5-8BU                 |                      |
|                  | Weidmuller      | AWG24           | H0.25/12                  | PZ6 roto             |
|                  |                 | AWG22           | H0.34/12                  |                      |
|                  |                 | AWG20           | H0.5/14                   |                      |
|                  |                 | AWG18           | H0.75/14                  |                      |
|                  |                 | AWG16           | H1.5/14                   |                      |
|                  |                 | AWG14           | H2.5/15D                  |                      |
| Round ferrule    | Nichifu         | AWG22-<br>AWG16 | TGV TC-1.25-9T            | NH11<br>NH32<br>NH65 |

Note: □□ of ferrule model is for color (Ex: YE = Yellow)

#### When an electric wire is connected directly (J,E,P type)

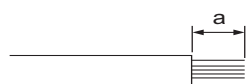

| Model    | Strip length "a"     |
|----------|----------------------|
| XW2R-J□□ | 9 mm                 |
| XW2R-E□□ | 7 mm                 |
| XW2R-P□□ | AWG28-16: 8 to 10 mm |
|          | AWG14: 9 to 10 mm    |

#### Mounting Units to and Removing Units from DIN Track

##### Mounting Procedure

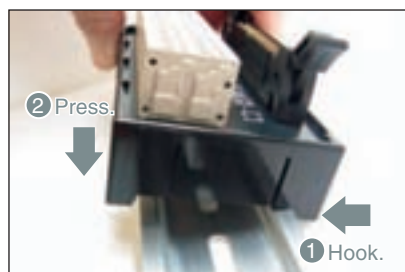

- Hook the Unit on the DIN Track.
- Press the Unit onto the DIN Track to secure it.

##### Removal Procedure

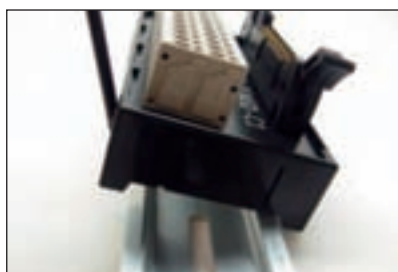

- Insert a flat-blade screwdriver into the DIN Track lock.
- Move the screwdriver like a lever to free the lock.

## Connecting Spring cramp Terminals

### Using Ferrules

#### How to insert wire

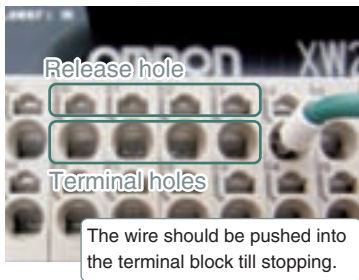

#### How to release wire



### Using Stripped Wires

#### Inserting and Removing Wires

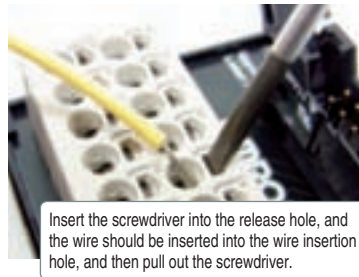

#### Inserting Wires

1. Press the a flat-blade screwdriver diagonally into the release hole. Press at an angle of  $10^\circ$  to  $15^\circ$ . If you press in the screwdriver correctly, you will feel the spring in the release hole.

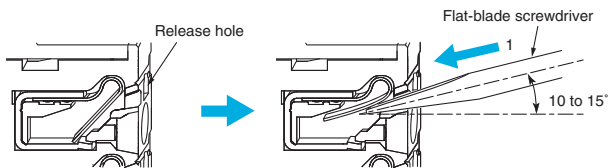

2. Leave the flat-blade screwdriver pressed into the release hole and insert the stranded wire or the solid wire into the terminal hole. Insert the stranded wire or the solid wire until the stripped portion is no longer visible to prevent shorting.

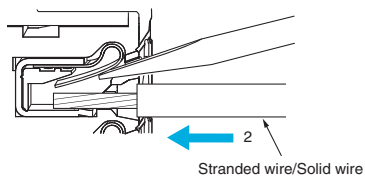

3. Remove the flat-blade screwdriver from the release hole.

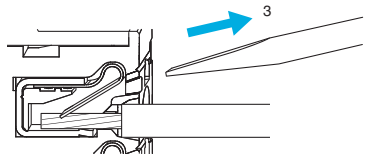

#### Removing Wires

1. Press the flat-blade screwdriver diagonally into the release hole. Press at an angle of  $10^\circ$  to  $15^\circ$ . If you press in the screwdriver correctly, you will feel the spring in the release hole.

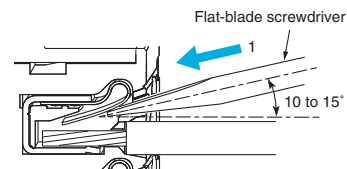

2. Leave the flat-blade screwdriver pressed into the release hole and pull out the wire.

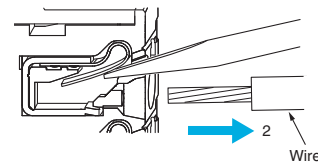

3. Remove the flat-blade screwdriver from the release hole.

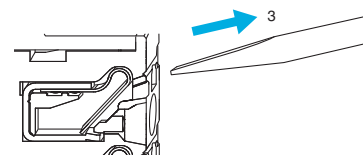

**Precautions for Safe Use**

- Do not press the flat-blade screwdriver straight into the release hole. Doing so may break the terminal block.

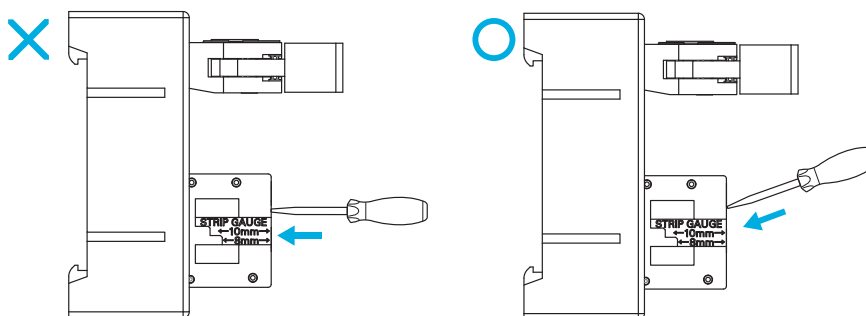

- When you insert a flat-blade screwdriver into a release hole, press it down with a force of 30 N max. Applying excessive force may damage the terminal block.
- Do not tilt or twist the flat-blade screwdriver while it is pressed into the release hole. Doing so may break the terminal block.

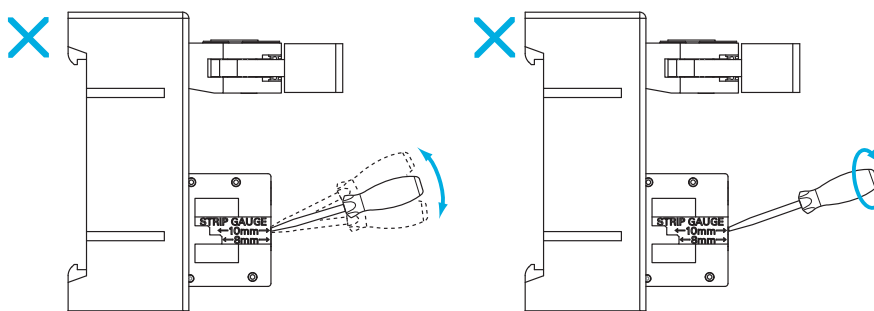

- Make sure that all wiring is correct.
- Do not bend the cable forcibly. Doing so may sever the cable.

**Use tool**

- Select a use tool from following table.

| Model    | Use tool               | Specialized tool and dimension                            |
|----------|------------------------|---|
| XW2R-J□□ | Phillips screwdriver   | JIS#2   |
| XW2R-E□□ | Flat-blade screwdriver | Model XW4Z-00B<br>Head of screwdriver is 0.4 x 2.5mm max. |
| XW2R-P□□ |                        |   |

**Flat-blade screwdriver**

| Model    |
|----------|
| XW4Z-00B |

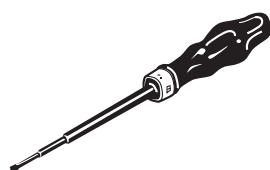

**Bending Radius of Connecting Cables**

- To prevent damaging the Connecting Cables, use the following minimum bending radii as guidelines.

XW2Z - □ □ □ □ □

| End of model number | Minimum bending radius |
|---------------------|------------------------|
| BF-L, EE-L, FF-L    | 66 mm                  |
| A                   | 67.2 mm                |
| EE                  | 83 mm                  |
| B, D, K, L, N       | 88 mm                  |

**For checking electrical continuity**

- XW2R-E□□ type: There is no electrical continuity in the screw, Please confirm it at hole for confirming continuity or wiring part.

## Terms and Conditions Agreement

### Read and understand this catalog.

Please read and understand this catalog before purchasing the products. Please consult your OMRON representative if you have any questions or comments.

### Warranties.

(a) Exclusive Warranty. Omron's exclusive warranty is that the Products will be free from defects in materials and workmanship for a period of twelve months from the date of sale by Omron (or such other period expressed in writing by Omron). Omron disclaims all other warranties, express or implied.

(b) Limitations. OMRON MAKES NO WARRANTY OR REPRESENTATION, EXPRESS OR IMPLIED, ABOUT NON-INFRINGEMENT, MERCHANTABILITY OR FITNESS FOR A PARTICULAR PURPOSE OF THE PRODUCTS. BUYER ACKNOWLEDGES THAT IT ALONE HAS DETERMINED THAT THE PRODUCTS WILL SUITABLY MEET THE REQUIREMENTS OF THEIR INTENDED USE.

Omron further disclaims all warranties and responsibility of any type for claims or expenses based on infringement by the Products or otherwise of any intellectual property right. (c) Buyer Remedy. Omron's sole obligation hereunder shall be, at Omron's election, to (i) replace (in the form originally shipped with Buyer responsible for labor charges for removal or replacement thereof) the non-complying Product, (ii) repair the non-complying Product, or (iii) repay or credit Buyer an amount equal to the purchase price of the non-complying Product; provided that in no event shall Omron be responsible for warranty, repair, indemnity or any other claims or expenses regarding the Products unless Omron's analysis confirms that the Products were properly handled, stored, installed and maintained and not subject to contamination, abuse, misuse or inappropriate modification. Return of any Products by Buyer must be approved in writing by Omron before shipment. Omron Companies shall not be liable for the suitability or unsuitability or the results from the use of Products in combination with any electrical or electronic components, circuits, system assemblies or any other materials or substances or environments. Any advice, recommendations or information given orally or in writing, are not to be construed as an amendment or addition to the above warranty.

See <http://www.omron.com/global/> or contact your Omron representative for published information.

### Limitation on Liability; Etc.

OMRON COMPANIES SHALL NOT BE LIABLE FOR SPECIAL, INDIRECT, INCIDENTAL, OR CONSEQUENTIAL DAMAGES, LOSS OF PROFITS OR PRODUCTION OR COMMERCIAL LOSS IN ANY WAY CONNECTED WITH THE PRODUCTS, WHETHER SUCH CLAIM IS BASED IN CONTRACT, WARRANTY, NEGLIGENCE OR STRICT LIABILITY.

Further, in no event shall liability of Omron Companies exceed the individual price of the Product on which liability is asserted.

### Suitability of Use.

Omron Companies shall not be responsible for conformity with any standards, codes or regulations which apply to the combination of the Product in the Buyer's application or use of the Product. At Buyer's request, Omron will provide applicable third party certification documents identifying ratings and limitations of use which apply to the Product. This information by itself is not sufficient for a complete determination of the suitability of the Product in combination with the end product, machine, system, or other application or use. Buyer shall be solely responsible for determining appropriateness of the particular Product with respect to Buyer's application, product or system. Buyer shall take application responsibility in all cases.

NEVER USE THE PRODUCT FOR AN APPLICATION INVOLVING SERIOUS RISK TO LIFE OR PROPERTY OR IN LARGE QUANTITIES WITHOUT ENSURING THAT THE SYSTEM AS A WHOLE HAS BEEN DESIGNED TO ADDRESS THE RISKS, AND THAT THE OMRON PRODUCT(S) IS PROPERLY RATED AND INSTALLED FOR THE INTENDED USE WITHIN THE OVERALL EQUIPMENT OR SYSTEM.

### Programmable Products.

Omron Companies shall not be responsible for the user's programming of a programmable Product, or any consequence thereof.

### Performance Data.

Data presented in Omron Company websites, catalogs and other materials is provided as a guide for the user in determining suitability and does not constitute a warranty. It may represent the result of Omron's test conditions, and the user must correlate it to actual application requirements. Actual performance is subject to the Omron's Warranty and Limitations of Liability.

### Change in Specifications.

Product specifications and accessories may be changed at any time based on improvements and other reasons. It is our practice to change part numbers when published ratings or features are changed, or when significant construction changes are made. However, some specifications of the Product may be changed without any notice. When in doubt, special part numbers may be assigned to fix or establish key specifications for your application. Please consult with your Omron's representative at any time to confirm actual specifications of purchased Product.

### Errors and Omissions.

Information presented by Omron Companies has been checked and is believed to be accurate; however, no responsibility is assumed for clerical, typographical or proofreading errors or omissions.

2015.1

In the interest of product improvement, specifications are subject to change without notice.

**OMRON Corporation**  
Industrial Automation Company

<http://www.ia.omron.com/>

(c)Copyright OMRON Corporation 2015 All Right Reserved.