

XS3F Sockets on One Cable End

Model Number Legend

Use this model number legend to identify products from their model number. When ordering, use a model number from the table in *Ordering Information*.

XS3F- **2** **-** **-**

1
2
3
4
5
6

1. Fastening Method

- M: M8
- S: S8
- E: M8
SUS316L Lock

2. Connector Poles

- 3: 3 poles
- 4: 4 poles
- 5: 5 poles

3. Cable Connection Direction

- 1: Straight
- 2: Right-angle

4. Connections

- Pin No.
- ① ③ ④
- 3: Brown Blue Black
- Pin No.
- ① ② ③ ④
- 4: Brown White Blue Black
- Pin No.
- ① ② ③ ④ ⑤
- 5: Brown White Blue Black Gray

5. Cable Length

- 01: 1 m
- 02: 2 m
- 05: 5 m
- 10: 10 m

6. Cable Specifications

- A: Standard cable
- R: Vibration-proof robot cable
- PR: Oil-resistant Polyurethane Robot cable

Mating Connectors

Item	Model
XS3F(M8)	XS3M (M8/S8), XS3H (M8), XS3W (M8)
XS3F(S8)	XS3M (M8/S8), XS3H (M8), XS3W (M8)

Note: M8 screw-on models and S8 snap-in models cannot be connected to each other.

Ordering Information

M8 Screw-on Connectors

Cable Specifications	No. of cable cores	Cable connection direction	Cable length L (m)	Model
Standard cable	3	Straight	2	XS3F-M321-302-A
			5	XS3F-M321-305-A
		Right-angle	2	XS3F-M322-302-A
			5	XS3F-M322-305-A
Vibration-proof robot cable	3	Straight	2	XS3F-M321-302-R
			5	XS3F-M321-305-R
		Right-angle	2	XS3F-M322-302-R
			5	XS3F-M322-305-R
Standard cable	4	Straight	2	XS3F-M421-402-A
			5	XS3F-M421-405-A
		Right-angle	2	XS3F-M422-402-A
			5	XS3F-M422-405-A
Vibration-proof robot cable	4	Straight	1	XS3F-M421-401-R
			2	XS3F-M421-402-R
			5	XS3F-M421-405-R
		Right-angle	1	XS3F-M422-401-R
			2	XS3F-M422-402-R
			5	XS3F-M422-405-R
Standard SUS316L cable lock	4	Straight	2	XS3F-E421-402-A
			5	XS3F-E421-405-A
		Right-angle	2	XS3F-E422-402-A
			5	XS3F-E422-405-A
Oil-resistant Polyurethane Robot cable	4	Straight	2	XS3F-M421-402-PR
			5	XS3F-M421-405-PR
		Right-angle	1	XS3F-M422-401-PR
			2	XS3F-M422-402-PR
			5	XS3F-M422-405-PR
			5	XS3F-M422-405-PR
Standard cable	5	Straight	2	XS3F-M521-502-A
			5	XS3F-M521-505-A
			10	XS3F-M521-510-A
		Right-angle	2	XS3F-M522-502-A
			5	XS3F-M522-505-A
			10	XS3F-M522-510-A

S8 Snap-in Connectors

Cable Specifications	No. of cable cores	Cable connection direction	Cable length L (m)	Model
Vibration-proof robot cable	4	Straight	1	XS3F-S421-401-R
			2	XS3F-S421-402-R
			5	XS3F-S421-405-R
		Right-angle	1	XS3F-S422-401-R
			2	XS3F-S422-402-R
			5	XS3F-S422-405-R

Dimensions

● M8 3 pin Screw-on Connectors with Vibration-proof Robot Cable/Standard Cable **XS3F-M32□-3□□-□**

Straight Connectors

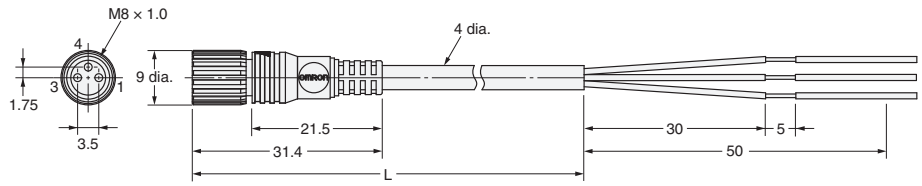

Right-angle Connectors

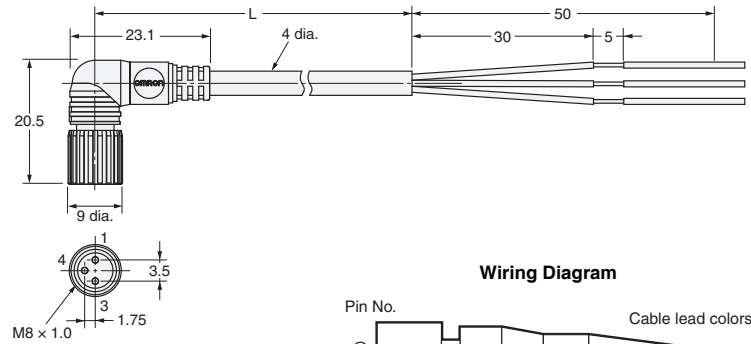

Wiring Diagram

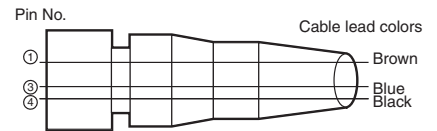

● M8 4 pin Screw-on Connectors with Vibration-proof Robot Cable/Standard Cable **XS3F-□42□-4□□-□**

Straight Connectors

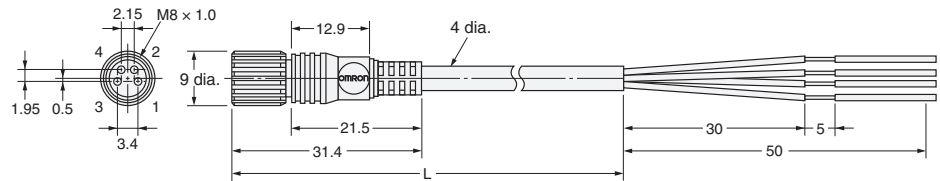

Right-angle Connectors

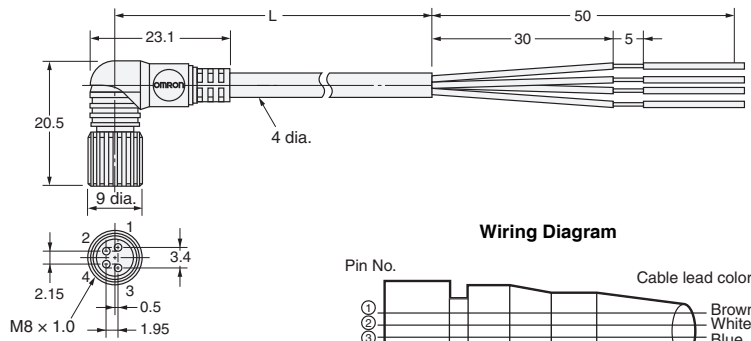

Wiring Diagram

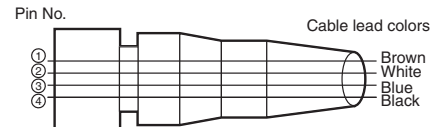

● M8 4 pin Screw-on Connectors with Oil-resistant Polyurethane Robot Cable

XS3F-M42□-40□-PR

Straight Connectors

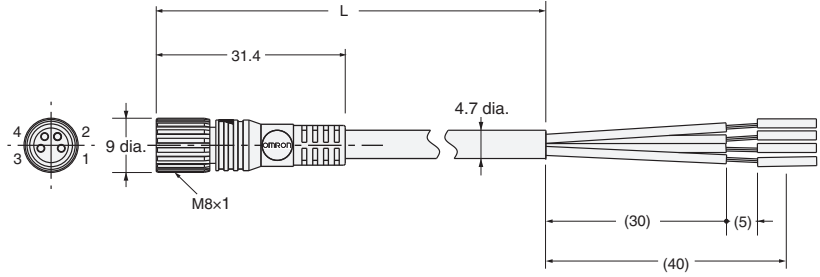

Right-angle Connectors

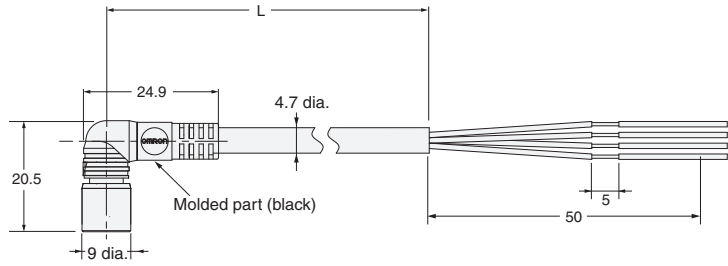

Wiring Diagram

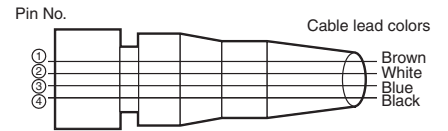
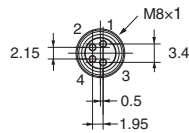

● M8 5 pin Screw-on Connectors with Standard Cable

XS3F-M52□-5□□-A

Straight Connectors

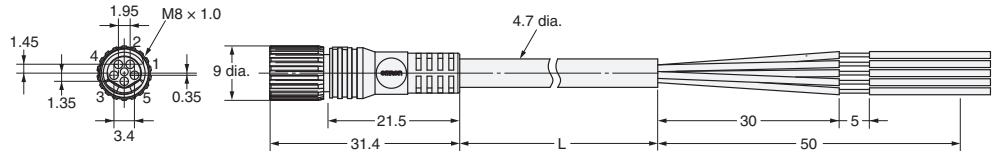

Right-angle Connectors

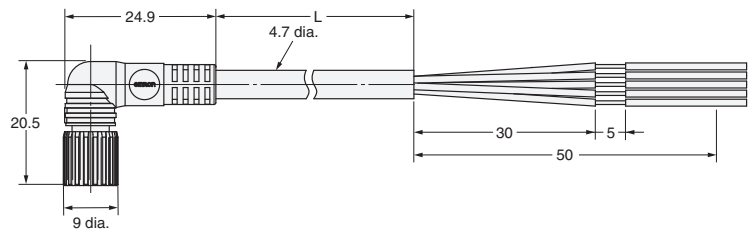

Wiring Diagram

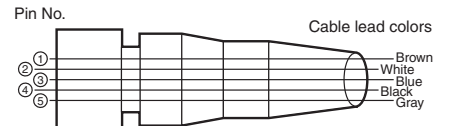
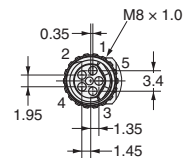

● S8 Snap-in Connectors with Vibration-proof Robot Cable

XS3F-S42□-4□□-R

Straight Connectors

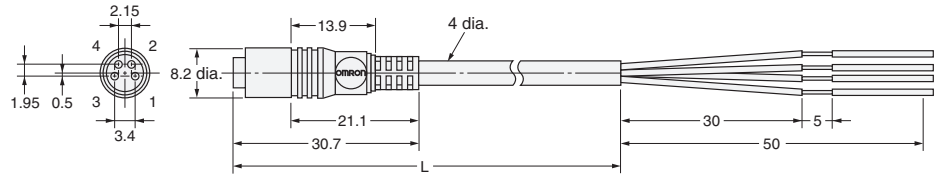

Right-angle Connectors

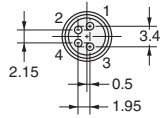
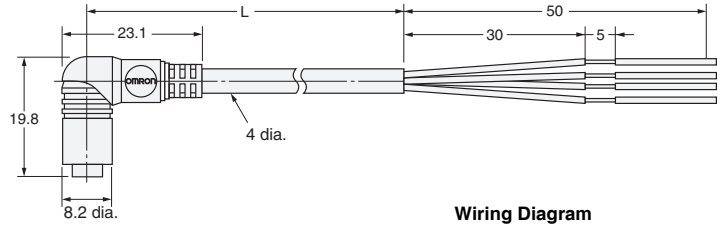

Wiring Diagram

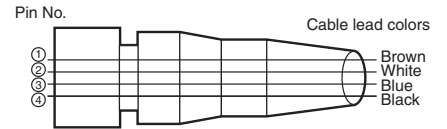

XS3H Plugs on One Cable End

Model Number Legend

Use this model number legend to identify products from their model number. When ordering, use a model number from the table in *Ordering Information*.

XS3H- **2** **-** **-**

1
2
3
4
5
6

1. Fastening Method

M: M8
S: S8

3. Cable Connection Direction

1: Straight
2: Right-angle

5. Cable Length

C3: 0.3 m
01: 1 m
02: 2 m
05: 5 m

2. Connector Poles

3: 3 poles
4: 4 poles

4. Connections

Pin No.
① ③ ④
3: Brown Blue Black
Pin No.
① ② ③ ④
4: Brown White Blue Black

6. Cable Specifications

R: Vibration-proof robot cable
PR: Oil-resistant Polyurethane Robot cable

Mating Connectors

Item	Model
XS3H(M8)	XS3F (M8), XS3W (M8), XS3P (M8)
XS3H(S8)	XS3F (S8), XS3W (S8), XS3P (S8)

Note: M8 screw-on models and S8 snap-in models cannot be connected to each other.

Ordering Information

M8 Screw-on Connectors

Cable Specifications	No. of cable cores	Cable connection direction	Cable length L (m)	Model
Vibration-proof Robot cable	3	Straight	0.3	XS3H-M321-3C3-R
			1	XS3H-M321-301-R
	4	Straight	0.3	XS3H-M421-4C3-R
			1	XS3H-M421-401-R
		Right-angle	0.3	XS3H-M422-4C3-R
			1	XS3H-M422-401-R
Oil-resistant Polyurethane Robot cable	4	Straight	2	XS3H-M421-402-PR
			5	XS3H-M421-405-PR
		Right-angle	1	XS3H-M422-401-PR
			2	XS3H-M422-402-PR
			5	XS3H-M422-405-PR
			5	XS3H-M422-405-PR

S8 Snap-in Connectors

Cable Specifications	No. of cable cores	Cable connection direction	Cable length L (m)	Model
Vibration-proof Robot cable	4	Straight	0.3	XS3H-S421-4C3-R
			1	XS3H-S421-401-R
		Right-angle	0.3	XS3H-S422-4C3-R
			1	XS3H-S422-401-R

Dimensions

● M8 3 pin Screw-on Connectors with Vibration-proof Robot Cable

XS3H-M321-3□□-R

Straight Connectors

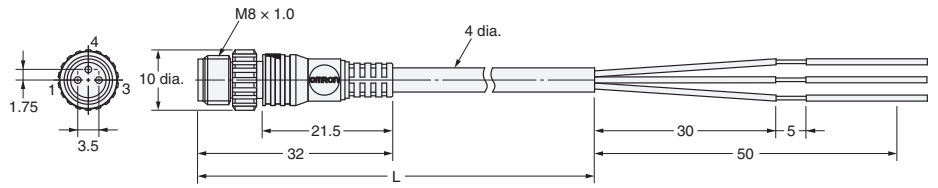

Wiring Diagram

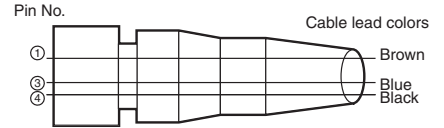

● M8 4 pin Screw-on Connectors with Vibration-proof Robot Cable

XS3H-M42□-4□□-R

Straight Connectors

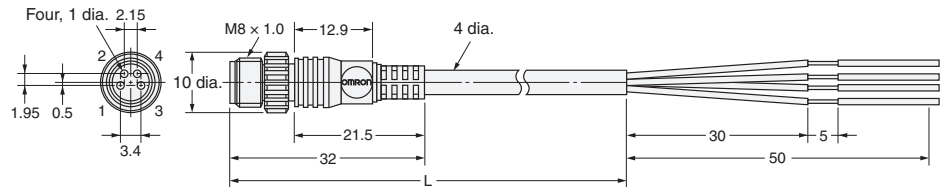
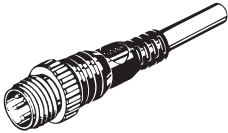

Right-angle Connectors

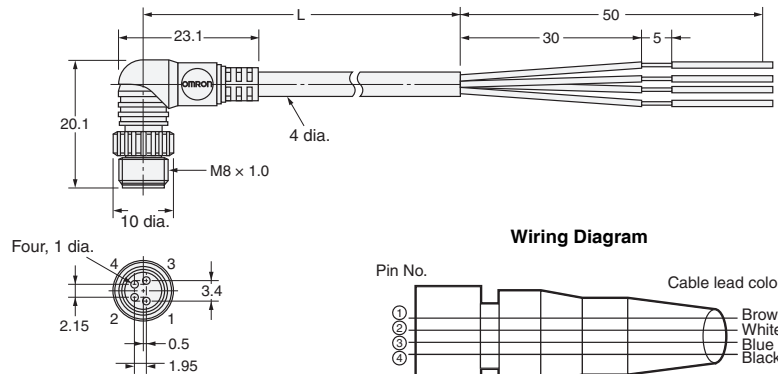

Wiring Diagram

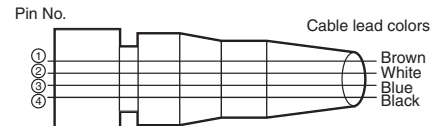

● M8 4 pin Screw-on Connectors with Oil-resistant Polyurethane Robot Cable

XS3H-M42□-40□-PR

Straight Connectors

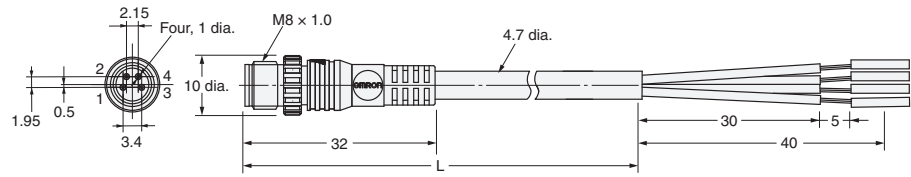

Right-angle Connectors

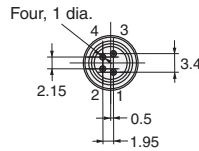
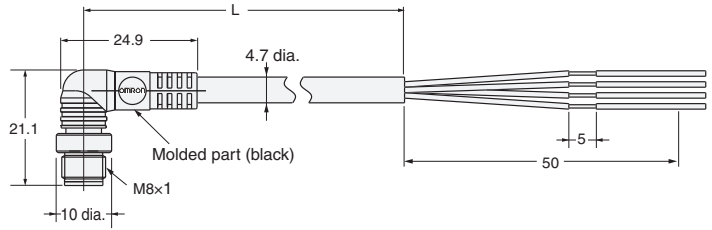

Wiring Diagram

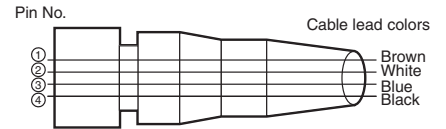

● S8 4 pin Snap-in Connectors with Vibration-proof Robot Cable

XS3H-S42□-4□□-R

Straight Connectors

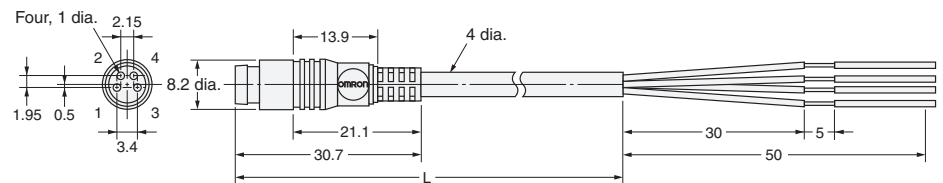
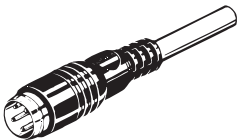

Right-angle Connectors

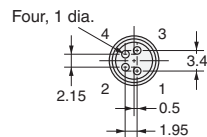
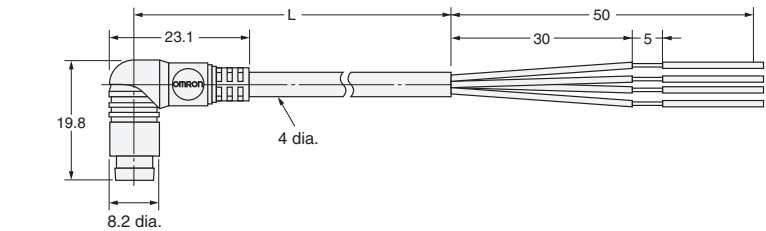

Wiring Diagram

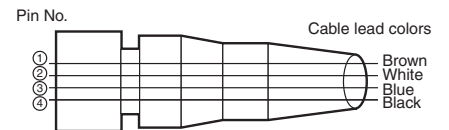

XS3P Panel-mounting Sockets for Terminal Boxes

Mating Connectors

Item	Model
XS3P(M8)	XS3H (M8), XS3W (M8)
XS3P(S8)	XS3H (S8), XS3W (S8)

Note: M8 screw-on models and S8 snap-in models cannot be connected to each other.

Ordering Information

Connection method	Panel mounting	Pin shape	Applicable wires	Model	Minimum order
M8 screw-on	Front lock or rear lock	DIP pins	---	XS3P-M421-1	50
		Solder cup pins	AWG24 max.	XS3P-M421-2	
S8 snap-in	Front lock or rear lock	Solder cup pins	AWG24 max.	XS3P-M422-2	
		DIP pins	---	XS3P-S421-1	
		Solder cup pins	AWG24 max.	XS3P-S421-2	

Note: Orders are accepted in multiples of the minimum order.

Safety Precautions

In addition to the following information, also refer to *Safety Precautions* on page 23

Precautions for Correct Use

Panel Mounting

- When mounting XS3P Panel-mounting Connectors to panels, refer to *Panel-mounting Dimensions* and provide rubber bushings and nuts for the Connectors. Apply a tightening torque of between 0.4 and 0.6 N·m to mount the Connectors.

Dimensions

- M8 Screw-on Sockets with DIP Pins
- M8 Screw-on Sockets with Solder Cup Pins
- M8 Screw-on Sockets with Solder Cup Pins

XS3P-M421-1
XS3P-M421-2
XS3P-M422-2

XS3P-M421-1 (DIP Pins)
Front lock or rear lock

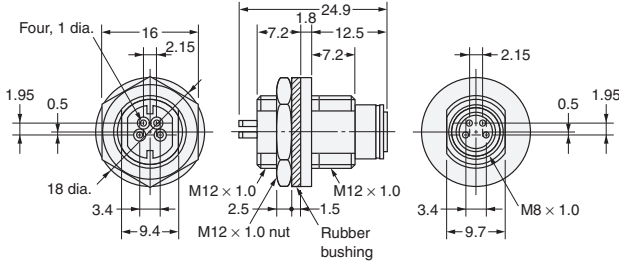

XS3P-M421-2 (Solder Cup Pins)
Front lock or rear lock

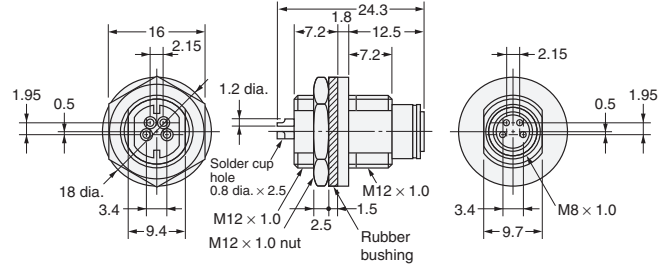

XS3P-M422-2 (Solder Cup Pins), Rear Lock Slim Models

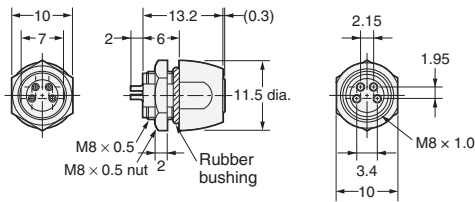

- S8 Snap-in Sockets with DIP Pins
- S8 Snap-in Sockets with Solder Cup Pins

XS3P-S421-1
XS3P-S421-2

XS3P-S421-1 (DIP Pins)
Front lock or rear lock

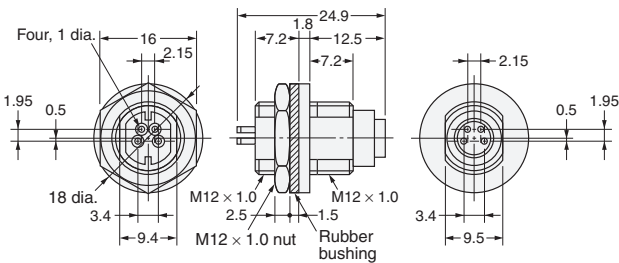

XS3P-S421-2 (Solder Cup Pins)
Front lock or rear lock

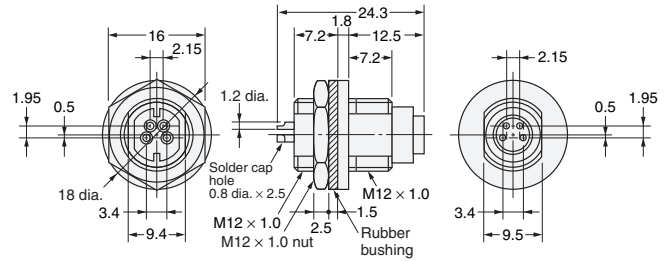

Mounting Dimensions for XS3P Screw-on Models and Snap-in Models

Panel Cutouts

XS3P-□421-□

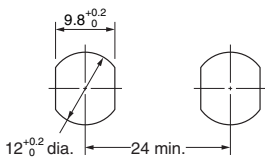

Note: The panel thickness is 1 to 3 mm.

XS3P-M422-2

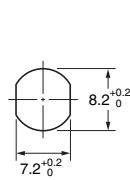

PCB-mounting Dimensions

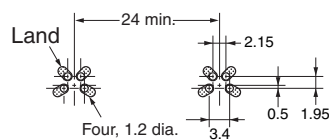

Note: The panel thickness is 2.4 mm maximum.

Panel-mounting Dimensions

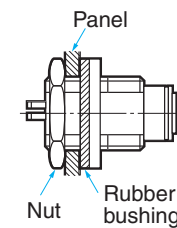

Front Lock

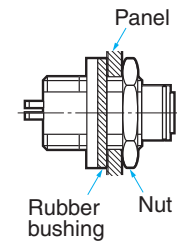

XS3M Sensor Embedded Plugs

Mating Connectors

Item	Model
XS3M	XS3F (M8/S8), XS3W (M8/S8)

Note: The plug can be connected to both M8 screw-on and S8 snap-in models.

Ordering Information

Connection method	Pin shape	Applicable wires	Model	Minimum order
Embedded model	DIP pins	---	XS3M-K421-1	200
	Solder cup pins	AWG26 max.	XS3M-K421-2	

Note: Orders are accepted in multiples of the minimum order.

Dimensions

(Unit: mm)

<ul style="list-style-type: none"> ● Embedded Plugs with Screw Threads and DIP Pins ● Embedded Plugs with Screw Threads and Solder Cup Pins 	<p>XS3M-K421-1</p> <p>XS3M-K421-2</p>
---------------------------------------------------------------------------------------------------------------------------------------------------------------------	-----------------------------------------------------

XS3M-K421-1

Embedded Model with DIP Pins

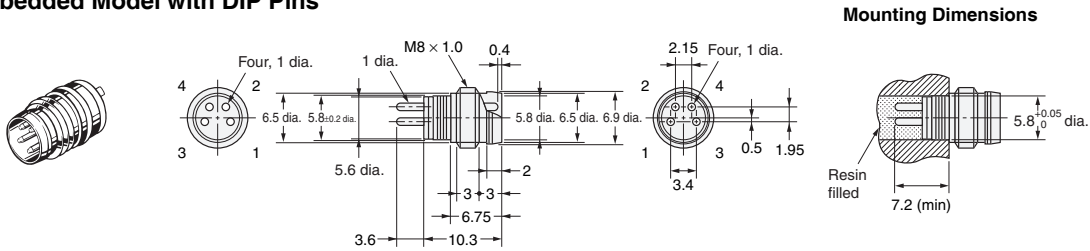

XS3M-K421-2

Embedded Model with Solder Cup Pins

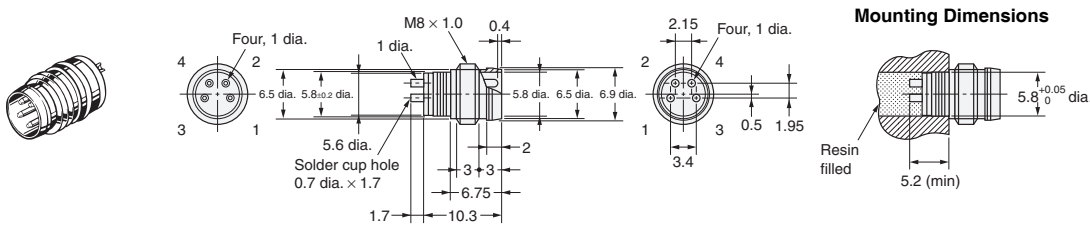

XS3M Panel-mounting Plugs

Mating Connectors

Item	Model
XS3M-M524-1□	XS3F-M52□-5□□-A

Ordering Information

Lock method	Pin shape	Shield pin	Applicable wires	Model
Front lock	DIP pins 4.5 mm (for either round holes or solder cups)	No	AWG26 max.	XS3M-M524-10
		Yes		XS3M-M524-11

Note: Orders are accepted in multiples of the minimum order.

Dimensions

(Unit: mm)

● Front lock DIP pins (5 pins) XS3M-M524-□□

XS3M-M524-10

Front Lock with DIP Pins 4.5 mm (for Either Round Holes or Solder Cups), Without Shield Pin

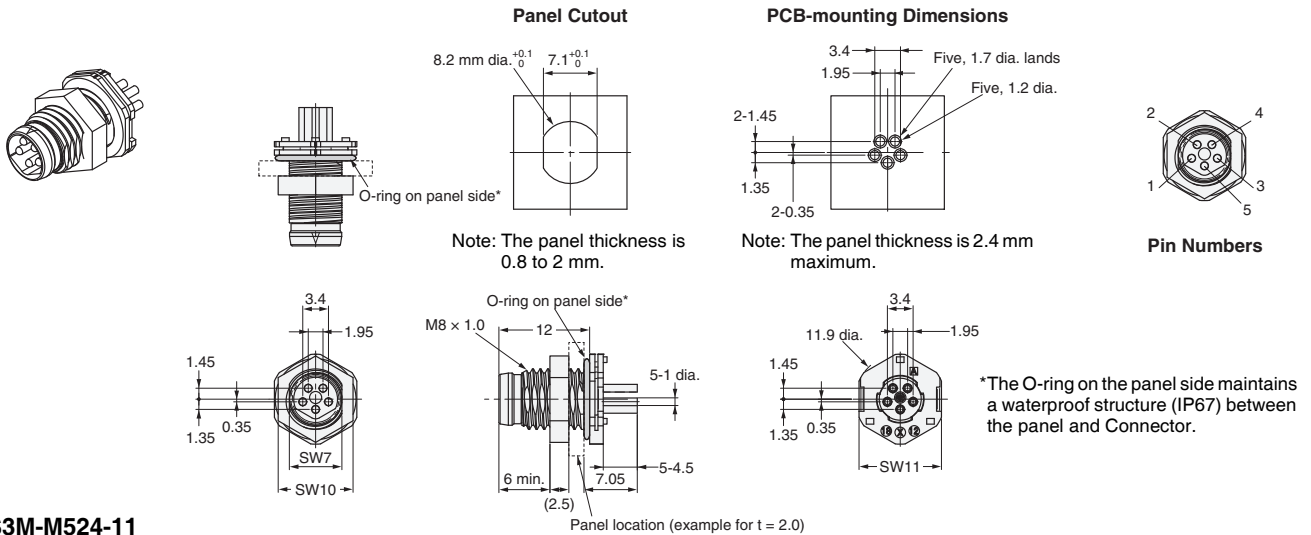

XS3M-M524-11

Front Lock with DIP Pins 4.5 mm (for Either Round Holes or Solder Cups), With Shield Pin

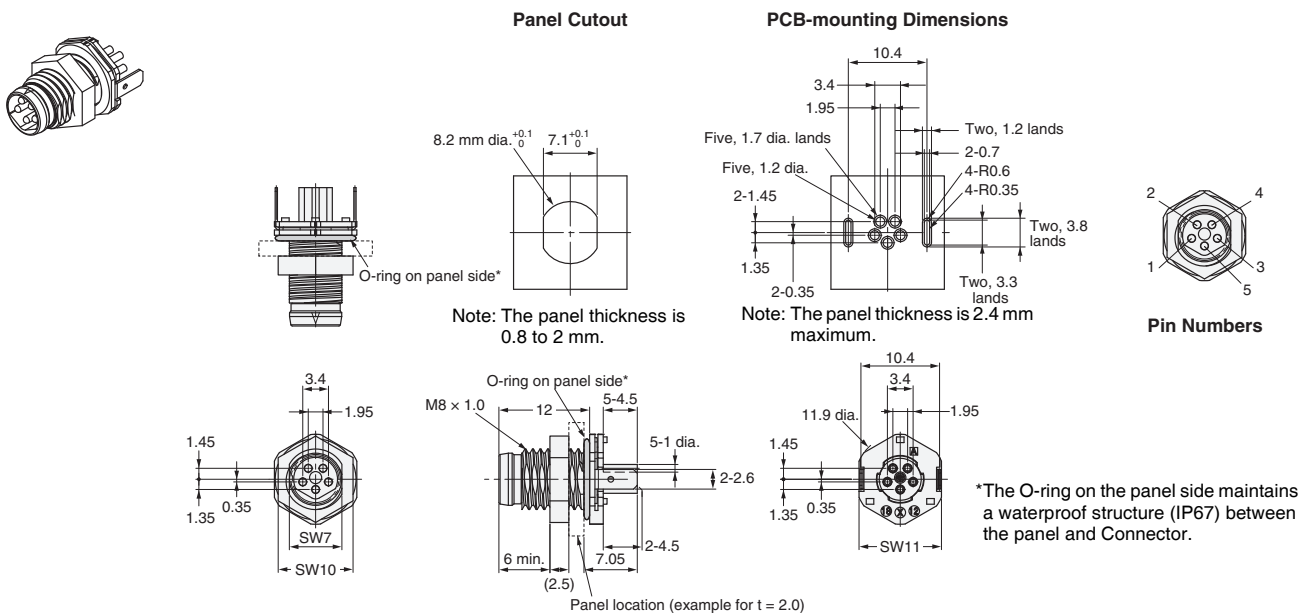

Safety Precautions

In addition to the following information, also refer to *Safety Precautions* on page 23

Precautions for Correct Use

XS3M-M524-□□ Mating

To mate the Connectors, align the mating marks on the Plug and Socket (see following figure), insert the Connectors completely, and tighten the lock nut, being careful not to damage the threads.

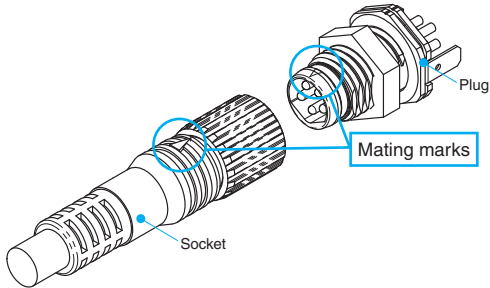

XS3M-M524-□□ Panel Mounting

After you mount the Connector to the panel, attach the nut and tighten it to a suitable torque (0.4 N·m).

XS3 M8/S8 Connector Cover

Dust Cover

XS3Z-13

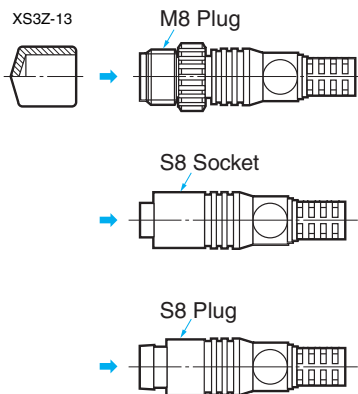

XS3Z-15

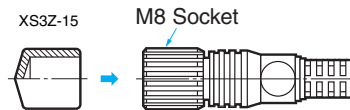

The Dust Cover is for dust prevention and does not ensure IP67. When mounting the Dust Cover to a Connector, be sure to press the Dust Cover onto the Connector until the Connector is fully inserted into the Dust Cover.

Model	Material	Suitable connector	
		Model	Mounting portion
XS3Z-13	PVC resin/red	XS3H/XS3W/XS3R	M8 plug
		XS3F/XS3W	S8 socket
		XS3H/XS3W	S8 plug
		XS3M	M8/S8 plug
XS3Z-15		XS3F/XS3W/XS3R	M8 socket

XS3R Y-Joint Plug/Socket Connectors

Mating Connectors

Item	Model
XS3R(M8)	XS3F(M8)
	XS3H(M8)
	XS3W(M8)
	XS3P(M8)

Ordering Information

For M8 Connectors

Cable	Connector	Cable length L (m)	Model	Minimum order
With cable	Connectors on both cable ends	0.5	XS3R-M426-1C51-A	5
		1	XS3R-M426-1011-A	
		2	XS3R-M426-1021-A	
		3	XS3R-M426-1031-A	
	Connector on one cable end	2	XS3R-M426-1020-A	
Without cable	Connectors on both cable ends	---	XS3R-M426-1	10
		---	XS3R-M426-5	

Dimensions

(Unit: mm)

● Screw-on Models (M8)	With Standard Cable:	XS3R-M426-1□□□-A
	Without Cable:	XS3R-M426-□

XS3R-M426-1□□□-A

Connectors on Both Cable Ends (Y-Joint Plug/Socket)

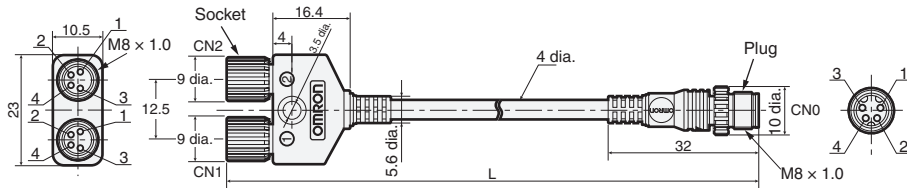

XS3R-

M426-1□□□-A

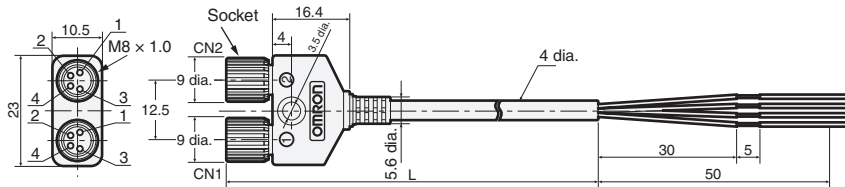

XS3R-M426-□

Connector on Both Ends (Y-Joint Plug/Socket) without Cable

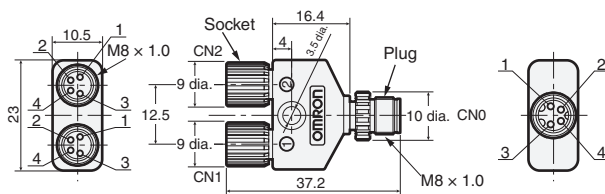

Wiring Diagram

XS3R-M426-1□□□-A

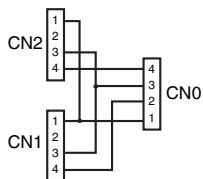

XS3R-M426-1□□□-A

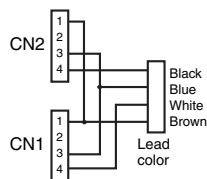

XS3R-M426-1

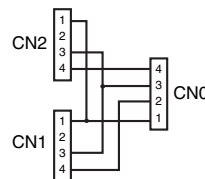

XS3R-M426-5

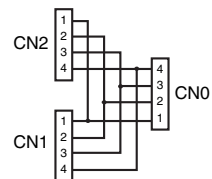

Safety Precautions

Precautions for Correct Use

Do not use the product in atmospheres or environments that exceed product ratings.

Connections

- The XS3 and XS2 Sensor I/O Connectors cannot be connected to each other.
- You cannot mate Connectors that have a different number of poles.
- When using Sensors with Connectors or Limit Switches, use the Sensor I/O Connectors specified in the catalog.
- Do not connect M8 screw-on models and S8 snap-in models together, otherwise the proper degree of protection of the Connectors will not be maintained.

Connector Connection and Disconnection

- Before connecting or disconnecting Connectors, make sure that no power is being supplied to the Connectors.
- When connecting or disconnecting Connectors, be sure to hold the Connectors by hand. Do not disconnect the Connectors by pulling the cable.
- Do not touch the engagement side of any Connector with wet hands. If there is any water on the Connector or near the Connector, be sure to wipe off the water before connecting or disconnecting the Connector, otherwise the Connector may short-circuit internally or not ensure good insulation.
- Make sure that engagement side of any Connector is free of metal dust or power.
- Do not use pliers to tighten mounting the thread bracket, otherwise the thread bracket may be damaged. Be sure to tighten each thread bracket by hand within a torque of 0.2 N·m. If the thread bracket is not tightened securely, the Connector may not maintain its proper degree of protection or the thread bracket may fall off due to vibration.
- When you tighten or loosen a lock nut, hold onto only the lock nut.
If you hold onto the cover or cable, excessive rotational force will be applied to the Connector and may damage it.
- Fully insert S8 snap-in models until the Connectors are hidden by the metal casing of the opposite parts, otherwise the Connectors will not maintain their proper degree of protection or the thread brackets may become loose due to vibration.

Degree of Protection

- Do not impose external force continuously on the joints of pin blocks and covers, otherwise the Connectors may not keep its proper degree of protection (i.e., IP67).
- Connectors are not fully watertight. Do not use them underwater.
- The Connectors are not oil-resistant. Do not use them where they would be subject to oil.
- If Connectors are used in places with vibration or shock, secure the engaged side of each Connector, otherwise the Connectors may be disconnected or fail to maintain their proper degree of protection.
- Connectors are of resin mold construction. Do not impose excessive force on them.

Storage

Do not store Connectors for long periods of time in the following locations

- Locations subject to dust or high humidity
- Locations subject to ammonia gas or sulfide gas

Installation

- Do not make any cable bends near the base of the Unit.
- Any bends made must have a minimum radius of 36 mm.